



All Brand Motorcycle Club

# Group Riding Guidelines

January, 99

These **Group Riding Guidelines** are the result of a lot of hard work by some of your fellow members, the Safety Lieutenants as listed below, and myself. We reviewed the Group Riding information from the *Shadow Riders Club - USA*, *Gold Wing Road Riders Association*, the State of Missouri Motorcycle Operations Handbook among other sources to help come up with these **Group Riding Guidelines**.

The designation of *Guidelines* needs to be understood in its purest sense. These are exactly that, *Guidelines*. They are meant to give everyone who rides with us the information they need to ride safely in a group (any number of motorcycles larger than one). It will provide the most common sense and safest formations and practices to achieve the goal of everyone riding and getting to their destination safely. They are to be implemented within the parameters of your own individual safety. **This is your responsibility**. If your decision is to not utilize these *Guidelines*, then you need to proceed to the destination chosen on your own so as not to jeopardize the safety of the group. This position is paramount to the concept of overall safety and individual responsibility.

We all feel that the *Guidelines* will make sense as written, but if there is any confusion or clarification needed, feel free to consult your Safety Officer, any of the Safety Lieutenants, Road Captains or myself for the help you need.

I hope you appreciate all the hard work and effort that went into these *Guidelines*. I want to personally thank the Safety Lieutenants for their efforts and thank you in advance for the time you are about to take in reading them.

Ride Hard, Ride Often and most of all Ride Safe!

The Shadow Riders Motorcycle Club would like to thank the following members, (past and present) for contributing to this document.

- Jay Weber, Lenny Morissette, Gary Sheerer, Ed Sallenbach, Paul Benson and Norm Pope

## 1.0 General Information

### 1.1 Purpose

The Shadow Riders Club-St. Louis, Inc. (here after referred to as SRC-STL), has created the Group Riding Guidelines to encourage the organizing of motorcycle group riding events that are both fun and safe for all participants. Common sense and experience are the key elements in making decisions on individual rider safety. The individual comfort level of each participating rider must be taken into account when organizing any group riding event.

### 1.2 Disclaimer

The SRC-STL, any Officer, Member, or Sponsor is not liable for any accident, loss of personal property or life as a result of using these 'Guidelines'. The contents are not 'Rules' nor do they imply mandatory compliance. Each participant, rider or member is totally responsible for his or her own personal safety at all times. The intent of this document is to provide such guidelines as to encourage and promote safe group riding practices.

## 2.0 Riding Formations

Three major riding formations are prevalent in group motorcycling: Staggered, Parade and Single File Formations. Under correct circumstances, each has it's own merit, however the Staggered Riding Formation is the preferred riding style primarily for safety considerations of those participating in group riding events.

### 2.1 Group Size

Different riding organizations may offer varied numbers as to what constitutes a maximum safe number of riders in a group. For SRC-STL, the number of bikes that can readily be seen effectively in the rear view mirror of a group leader is about 6 to 8 motorcycles.

### 2.2 Staggered Riding Formation, Defined

The Staggered Riding Formation is the preferred riding style for general riding for it's overall safety for all participants in a group ride. It is alternating rider positions on either side of the lane being traveled so that everyone is able to maintain visual contact of all other riders. (See Figure 1 - Staggered Riding Formation)

The Lead Road Captain (first rider in the group) will maintain a position that is to the left third of the lane and will set the pace for the group. The second rider will take a position behind and to the right third of the lane and **maintain a 1 second distance**. The third rider will align himself directly behind the Lead Road Captain (in the left third of the lane) **maintaining a 2 second distance** behind the Lead Road Captain and a **1 second distance** behind the second rider.

Regardless of the size of the group, this alternating positioning of motorcycles should be consistent. The odd numbered riders will be to the left third of the lane and the even numbered riders to the right third of the lane. The actual distance in feet between riders will vary depending on the speed of travel. Allow additional time between each rider when the weather or road conditions may impact the ability to brake effectively or to steer quickly out of an emergency situation.

**It is also important to keep the formation of motorcycles as close together as the road conditions will allow.**

**FIGURE 1 -- STAGGERED RIDING**

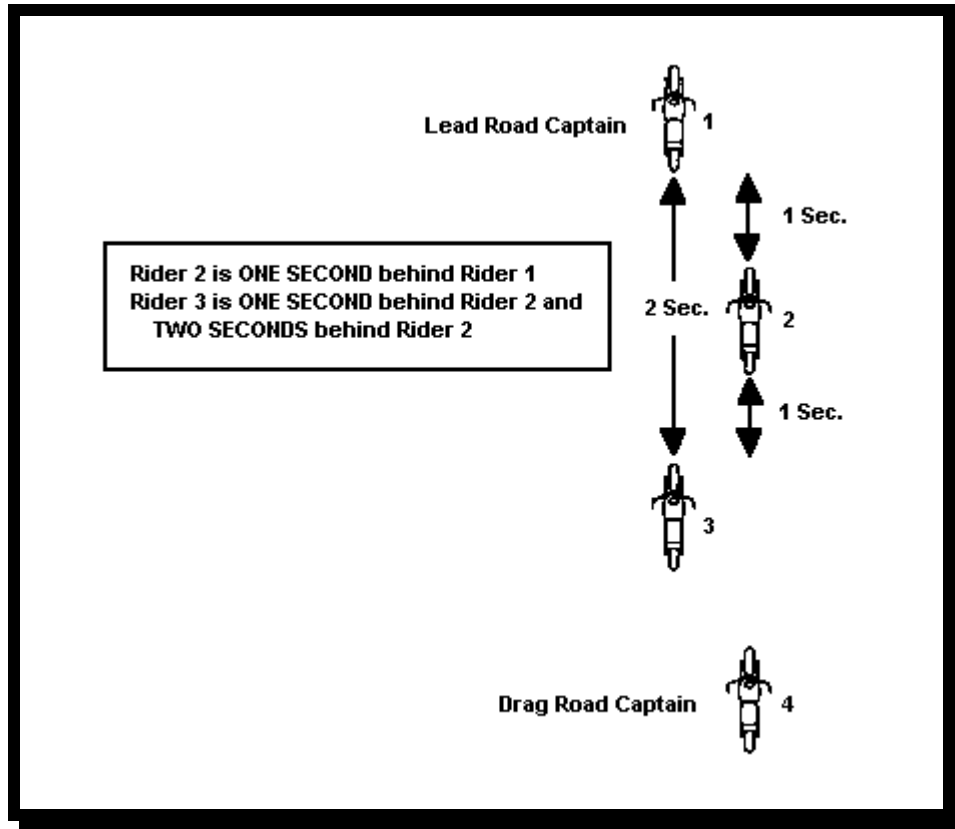

### **2.3 Parade Riding Formation (Pairing Up), Defined**

The Parade Riding Formation is best utilized for its intended purpose, which is riding in parades, or riding where speeds are at or below 25 mph for a significant duration.

Riders in position one and two are considered a 'Riding Pair', as are riders three and four, five and six and so forth. When the group is in a Staggered riding Formation and then comes to a stop sign or traffic signal, the pairs should be along side one another as in a Parade Formation. The rider to the right of the lane (even numbered rider) should pull along side of the rider at the left of the lane (odd numbered rider) when stopping.

When the need arises to communicate to another member of the group with the use of hand signals, such as the need to pull over for gasoline, or to indicate mechanical difficulties, the rider should attempt to pull along side the rider in their pair to communicate their intentions to pull out of formation.

**FIGURE 2 -- RIDERS PAIRING UP**

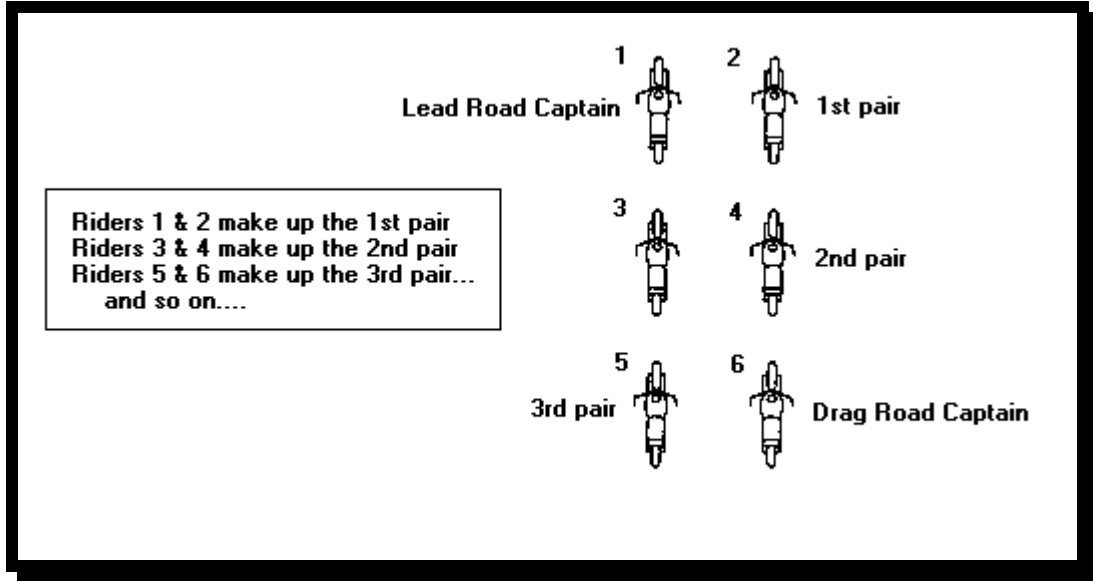

## 2.4 Single File Riding Formation, Defined

The Single File Formation has its advantages on open country roads, around disabled vehicles, narrow roads, and in parking lots and other reduced lane situations. Riding in Single File on winding back roads permits a rider to select their own line through curves.

Riding in single file is not practical for urban or city situations where automobile traffic is a real consideration. Riding in the Single File Formation extends the length of the group longer than what is practical. With lane changing of other vehicles and turns along the route, the group will most likely get separated.

## 2.5 Exiting the Formation

It is understood from the start of a group ride, that the individuals in the group will stay with the group until the next scheduled stop. If an individual plans to exit the formation at a predetermined point, that individual should inform the Drag Road Captain and the Lead Road Captain before the ride starts. Riders pulling out of formation without warning will be considered by the Drag Road Captain as being an emergency stop.

In the event an individual needs to exit the formation for unscheduled reasons, that individual should notify another rider (preferably the rider in the riding pair) of their intentions before exiting the group. A Drag Road Captain will always pull off with any rider needing to pull out of formation for safety reasons.

## **Group Riding Guidelines - January, 99**

### **2.6 The Slinky Effect**

The Slinky Effect occurs when a rider in the group allows too much distance to develop between his or her motorcycle and the rider just ahead. Once this has occurred, the rider must then try to speed up to catch up and slow down to maintain the pace of the group. The other riders must then adjust their speed until the group is eventually reunited.

The Slinky Effect can frustrate the most experienced rider and is undesirable in any formation. It will not be a comfortable group ride if the riders are constantly readjusting their speed and having to pass other autos that were let into the middle of the formation due to inconsistent riding speeds.

### **2.7 Starting and Stopping**

When the group forms up, either at the beginning of a ride or after a stop, all riders are side by side in pairs (Parade Formation, see Figure 2 - Riders Pairing Up). When the group begins to roll, the Lead Road Captain (rider number 1) always takes the lead by proceeding first followed by the second, then the third and all other riders in that group so that the Staggered Riding Formation is established as soon as possible.

When stopping at a stop sign, the riders are to pull up into Parade Formation (pairs). Only one pair of bikes may proceed through the intersection at a time. The Lead Road Captain or rider to the left of the pair will always move first. The rider to the right may proceed as soon as he sees the rider to the left accelerating and will give the lead to the rider on the left to reestablish the Staggered Riding Formation. The second pair will then pull up and stop at the stop sign and will proceed in the same manner. The remaining riders will proceed in the same fashion until all the riders have passed through the intersection. The Lead Road Captain will compensate the speed of the group until all the riders in that group are reunited.

Only in the event of utilizing Sentry's for moving small groups through difficult traffic and intersections, will the previous procedure be altered.

## **3.0 Responsibilities**

All riders in group riding activities are responsible for understanding and using proper hand and turn signals, (See Figure 3 for a diagram of commonly used hand signals) and proper use of headlights

### **3.1 Use of Headlight**

During the day light hours, both the Lead Road Captain and the Drag Road Captain will have their headlights on HIGH BEAM. All other riders will keep their headlights on LOW BEAM. In night time driving, only the Lead Road Captain will set their headlight to HIGH BEAM. All other riders will leave their headlight set to LOW BEAM unless a rider feels it important to their own safety to utilize the High Beam setting for specific road conditions.

### **3.2 Use of Turn and Hand Signals**

In addition to the use of electronic turn signals, it is recommended that riders use hand signals as well. This will get the message back to the rest of the group quicker.

The Lead Road Captain will initiate all turning sequences and each rider in that group should respond by first turning on the appropriate turn signal, followed up with the appropriate hand signal.

## **Group Riding Guidelines - January, 99**

### **3.3 Responsibilities, Safety Lieutenants, Lead and Drag Road Captains**

The Safety Lieutenant and Road Captains will start positioning and assigning groups 30 minutes prior to departure time. All riders participating in the ride will need to be in formation 15 minutes before departure time.

The Safety Lieutenant will hold a pre-ride meeting of all the Road Captains 15 minutes prior to ride departure time to explain where the group is going and the route to get there. The scheduled stops will also be announced. If a map or set of directions for the ride are made available, the Safety Lieutenant will have a copy for reference and distribute as needed.

The Safety Lieutenant will determine the size of each group and designate which group number the Road Captains will be assigned. It is also important that the new or less experienced riders be pointed out so they can be placed in the riding position and group.

A pre-ride meeting will be held by the Lead and Drag Road Captains with their individual group 10 minutes prior to departure time. The Lead Road Captain should insure that all riders are familiar with the commonly used hand signals, preferred riding formations used by the group, and the route being taken before the ride begins.

To insure a safe distance between groups, the Lead Road Captain will allow 3-5 minutes between their group and the one in front of them.

The Lead Road Captain sets the pace for the group. When either passing, turning or merging, when it is safe to do so, the Lead Road Captain will initiate all maneuvers by use of signals with the group. Changing from the Staggered Riding Formation to other formations and back again will be initiated by the Lead Road Captain.

### **3.4 The Drag Road Captain's Responsibilities**

The Drag Road Captain is responsible for stopping to assist a rider who has to pull out of the group due to a problem. When making lane changes, the Lead Road Captain will initiate the lane change by signaling the lane change. The Drag Road Captain will change lanes first to block the lane before the group makes the lane change.

### **3.5 The Sentry's Responsibilities**

The Sentry shall precede the whole group to identify any dangerous situations along the route. This could include passing through intersections and assisting the group through hazardous road conditions and/or turns.

### **3.6 Individual Responsibility**

If anyone does not feel comfortable with riding in the group with the expectations mentioned in these guidelines, that person should pull out of the group and follow at a comfortable distance behind the group. Each and every person is responsible for his or her own safety at all times.

Group Riding Guidelines - January, 99

FIGURE 3 -- HAND SIGNALS

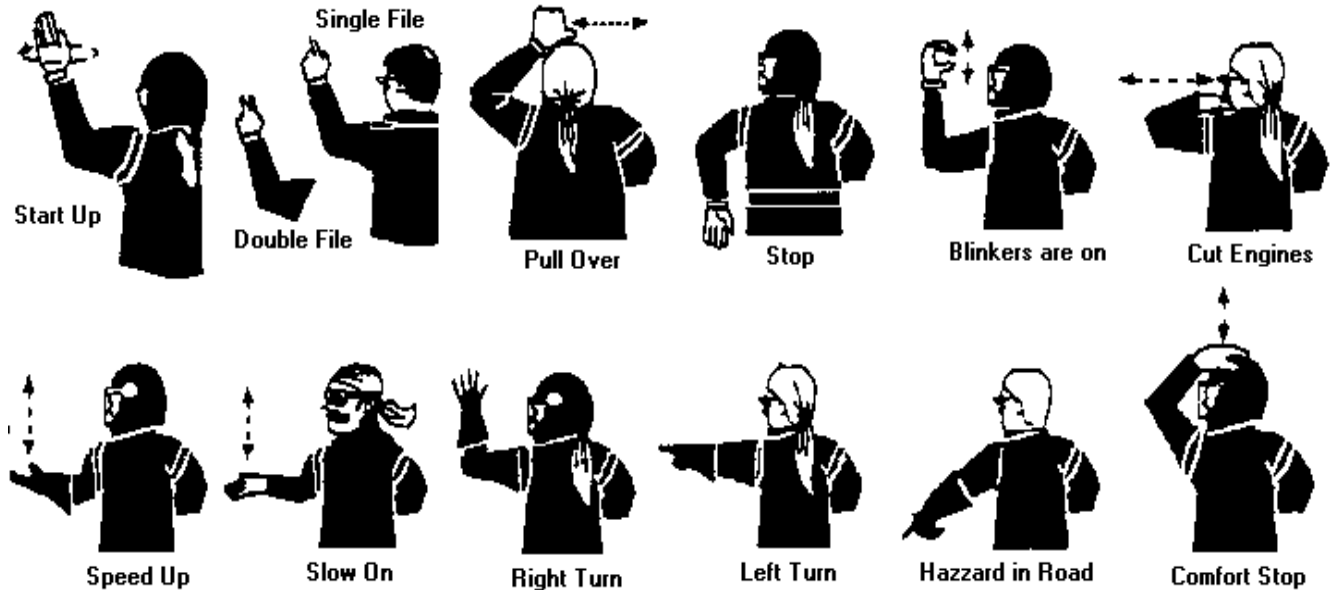

## TIPS FOR YOUR SAFETY

- Develop good eye habits. Look where you want to go. Focus on your intended path of travel. Your bike will only travel in the direction your head is turned and your eyes are focused.
- Keep your eyes up. Aim your vision well ahead.
- Always use both brakes at the same time to stop.
- Never brake or down shift while in a curve or leaning into a turn. Always do this prior to the curve or the turn. Accelerate out of a curve.
- Gas up prior to the start of the ride.
- Prior to riding, check your tires, the tire pressure, and the fluid levels.
- Know your motorcycle, and your riding limits.
- Most collisions involve riders who have “under” braked the front wheel and “over” braked the rear.
- Pass all hand signals from the rider in front of you to the riders behind you.
- When riding a passenger, train your passenger:
  - Instruct your passenger to sit as far forward as possible without crowding you.
  - Instruct your passenger to hold firmly to your waist, hips or belt, never your shoulders or neck.
  - Instruct your passenger to keep their feet on the pegs at all times, even when stopped or in turns.
  - Instruct your passenger to lean forward during acceleration.
  - Instruct your passenger to look over your shoulder that corresponds to the direction you are turning. As you turn left they look over your left shoulder, as you turn right they look over your right shoulder.